

Specifications

Description

Adcraft's Fresh Shot Countertop Steamer is perfect for keeping tortillas, pitas, bread and so much more hot and fresh at the push of a button. Great for use in any kitchen with its small footprint and compact size. This steamer accommodates one half-size pan. The easy to use push button operation provides a quick shot of heat in seconds that instantly heats up your food. The exterior of the unit is constructed of stainless steel and has a black powder coated top. The interior well is constructed of cast aluminum and is easy to clean. The self contained water reservoir allows for easy filling and disposing of water with no water line hook-up needed. This unit includes a stainless steel perforated half pan, an on/off rocker switch and comes with a 4' power cord with a NEMA 5-15 plug. This item is CE certified and backed by Adcraft's 1 year limited warranty.

Construction

- Exterior is constructed of heavy duty stainless steel
- Powder coated top
- Cast aluminum well
- Water reservoir holds up to 3 quarts of water

Operation

- Simple one push button that blasts steam in excess of 212°F that rejuvenates and heats up cold, pre-cooked food inside the well.
- Illuminated On/Off rocker switch located on the front of the unit lets you know when the unit is in operation.
- Pre-heat in only 30 minutes.

Electrical

- 120V, 1800W, 15 Amps
- 4' power cord with NEMA 5-15 plug

Model Features

- Includes half size perforated food pan
- Bakelite handle that is cool to touch
- Non-slip rubber feet for stability

Fresh Shot Countertop Steamer

Models:

- CTS-1800W



Certifications/Approvals



Warranty: This product is protected by Admiral Craft Equipment Corporation's one year limited warranty. Should your product fail under normal use it will be repaired or replaced up to one year from date of purchase.



Date: _____
Item No.: _____
Project No.: _____

Fresh Shot Countertop Steamer - CTS-1800W

Plan View

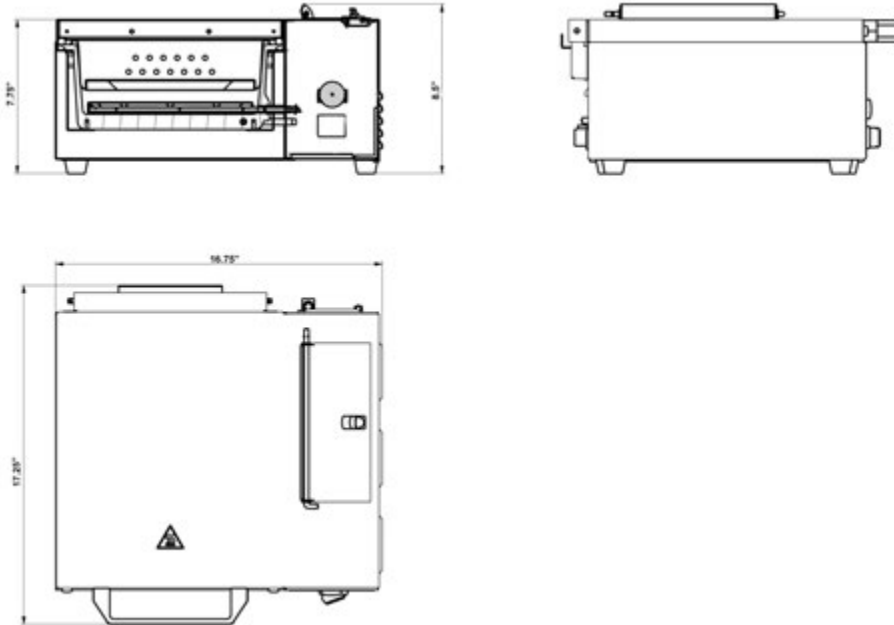

Specifications

Item Number	Item Dimensions	Volts	Wattage	Amps	NEMA Plug
CTS-1800W	16.75"W x 17.25"D x 8.5"H	120V	1800W	15	5-15P 

Overall height with lid open is 24"

Shipping Info

Item Number	Box Dimensions	Gross Weight	Net Weight
CTS-1800W	24"W x 22.5"D x 15.5"H	88 lbs	72.75 lbs